

User Guide

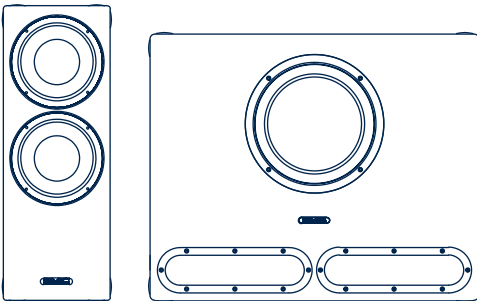

Model

Serial No.

Hand built by

ATL™
Advanced Transmission Line

○○○ **PMC**®

IMPORTANT



Warranty Certificate

Please take a few moments to complete the warranty card at the back of this booklet (or register at www.pmc-speakers.com) as this not only records the purchase of your loudspeakers, but also provides you with an opportunity to make suggestions and provide feedback directly to PMC.

Product Support

For product support, accessories or servicing advice, please contact a PMC authorised dealer/distributor. See www.pmc-speakers.com and click on 'Where to buy'.

Company Details

THE PROFESSIONAL MONITOR COMPANY LIMITED
HOLME COURT, BIGGLESWADE, SG18 9ST
T 0870 4441044 F 0870 4441045

email: sales@pmc-speakers.com web: www.pmc-speakers.com

© 2015 PMC. All rights reserved.

PMC stock code: 14767. Ref. no - 613

This document should not be construed as a commitment on the part of PMC. The information it contains is subject to change without notice. PMC assumes no responsibility for any errors within this document.

CE Conformity: PMC active loudspeakers conform to EC Directive LVD2006/95/EC and EMC 2004/108/EC.

WEEE European directive: PMC is a member of a National Compliance scheme and has gained the associated certification of compliance from the Environment Agency with the registration WEEE/GJ0101WU.

WEEE EU Directive

This symbol on the product, and in or on its packaging, indicates that this product must not be disposed of with other household waste. It is the responsibility of the owner to dispose of waste equipment via a designated collection point for the recycling of waste electrical and electronic equipment. The recycling of waste equipment is an attempt to conserve natural resources and ensures that it is recycled in a manner that protects human health and the environment. For more information about where to dispose of waste equipment for recycling, please contact your local waste/recycling authority or the dealer from whom you purchased the product.



A message from Peter Thomas:



Peter Thomas
Owner & Chief Designer



Our sole aim while designing loudspeakers is to recreate the true essence of an artist's intention, combining the ultimate level of sonic resolution with solid engineering principles.

We believe that the same loudspeaker can be used throughout the entire audio chain, from composer to studio or film stage, post-production or mastering and then, finally, the consumer. We also think that a well designed loudspeaker should be able to excel regardless of the audio genre, and reproduce spoken word, rock, pop, or classical music with the same precision and accuracy. Our unwavering passion for getting it right has made this goal possible.

Thank you for choosing PMC products. Please read this user guide and install your new **twotwo** subwoofer bearing in mind the advice given within.

A handwritten signature in grey ink that reads "P. Thomas". The signature is fluid and cursive, with a large initial "P" and "T".

Congratulations - You have joined the elite

PMC: the authority for quality sound.

Prince

Stevie Wonder

ESPN

BBC

Tony Bennett

JVC Studios

EMI

SONY

Coldplay

elbow

Over more than two decades PMC has earned an unrivalled reputation for creating the world's finest professional loudspeakers. Simply put, our loudspeakers provide a reference for the world's highest profile productions and events. They are found at every stage of the creative process, from conception to recording and broadcast and, of course, in the home.

Our client list reads like a who's who of the sonically aware, with Prince, Elbow, Stevie Wonder, Coldplay, Brian May, Universal, EMI, Sony, Pinewood Studios, Dreamworks, Capitol Studios and the BBC among the makers of movies and music who use our products.

Our loudspeakers were also used in the production of Titanic, Spiderman III, Iron Man 2, Finding Nemo, Pirates of the Caribbean III, and during broadcasts of the London Olympics, 2012.

UNIVERSAL MUSIC GROUP

Thomas Newman

Brian May

Kraftwerk

Royal College of Music

Warner Music

PINEWOOD STUDIOS

Capitol **STUDIOS**

Google

User Guide

Contents

- 7 General Usage Guidelines
- 8 Introduction
- 9 Unpacking and Care
- 10 PMC's **ATL™** – How the Advanced Transmission Line Works
- 11 System Description
- 12 User EQ Options
- 13 Connections
- 14 Running In
- 15 Applications – 2.1 Configurations
- 17 Applications – 5.1 Configurations
- 18 Applications – 7.1 Configurations
- 21 Positioning & Alignment
- 22 **twotwo sub1** Specifications
- 24 **twotwo sub2** Specifications
- 26 Operational Controls
- 29 Service
- 30 The PMC Range
- 31 Our Meticulous Care and Attention
- 32 Inspection Certificate
- 33 Warranty On-Line
- 34 Warranty Certificate – Part 1 – Your copy
- 35 Warranty Certificate – Part 2 – PMC's copy
- 36 Help us improve – Your Comments

General Usage Guidelines

- 1 Read these instructions and keep them in a safe place for future reference.
- 2 Heed all electrical safety warnings, including any on the loudspeaker itself.
- 3 Do not use the loudspeaker near water.
- 4 Do not install the loudspeaker near heat sources such as radiators, ovens or other very hot equipment, or in unventilated soffits or enclosures.
- 5 Do not attempt to service the equipment. There are no user-serviceable parts inside. Please refer all servicing to PMC authorised personnel.
- 6 Servicing is required when the apparatus is damaged, exposed to moisture, or exhibits a distinct or sudden change of operation or audio performance.
- 7 Unplug this product from both signal source and power during electrical storms, or when unused for extended periods of time.
- 8 Packaging material can pose danger to the young and vulnerable. Ensure these items are stored or disposed of safely.
- 9 The **twotwo** active subwoofers can produce high sound pressure levels. Exposure to high levels of sound has the potential to cause hearing damage. Use care when adjusting the system volume to ensure sound pressure levels remain within safe and comfortable limits.
- 10 Very powerful magnets are employed in the **twotwo** active subwoofers which may have a detrimental effect on magnetically-sensitive items if placed too close, such as CRT (tube-style) televisions or monitors, and media such as cassettes and videotapes.
- 11 The loudspeaker cabinet should only be cleaned with a dry, lint-free, cloth. Do not use solvents, abrasives, waxes or liquids as they may be detrimental to the finish.
- 12 To avoid damage to flooring the user should determine the suitability of either spikes or protective glides.
- 13 PMC has made efforts to provide accurate installation information and good quality fixings. However, PMC will not be held responsible or liable for injuries or property damage (direct, indirect or consequential) arising out of use or inability to use this product safely and properly.
- 14 This product may contain nuts.



Introduction

Thank you for choosing the PMC **twotwo** active subwoofer. This guide provides installation and operating instructions.

These active subwoofers can be used in a 2.1 configuration with **twotwo series** monitors to gain extra bass extension and headroom, or they can be used to reproduce a low frequency effects (LFE) channel in a surround system. Numerous configurations are possible, some of which are illustrated in this guide.

The electronics built into the subwoofer cabinets are identical for both sub models, and include an ultra-low distortion Class-D power amplifier, with DSP-based gain, filtering, and bass management functions. Balanced stereo analogue and AES3 digital inputs are accepted to feed the subwoofer system, and these input signals are also passed through to the analogue and digital outputs for connection with other devices. The outputs can be unprocessed or high-pass filtered, and with fixed or variable gain.

The input source, analogue input sensitivity, gain trim, and overall volume are all adjustable, as are the subwoofer's low-pass filter slope and frequency. Additionally, the phase can be adjusted and a single parametric equaliser is provided to assist with in-room alignment. The analogue and digital outputs can be high-pass filtered, if required, to feed satellite speakers in a 2.1 configuration.

This subwoofer builds upon PMC's world-class design pedigree, combining the finest drivers available with the unique **ATL™** (Advanced Transmission Line) bass loading principle, sophisticated Class-D amplification, and ultra-precise DSP control. PMC's unique **ATL™** technology uses contemporary materials to provide optimised absorption of unwanted low-midrange energy within the cabinet, while extending bass output significantly with negligible harmonic distortion.

The two long-throw bass drivers employed in the **twotwo sub1** subwoofer are a bespoke PMC design using natural materials, with an ultra-light and ultra-stiff doped-paper cone to deliver unparalleled transient response. The **twotwo sub1** cabinet has a small footprint, making it more convenient and easier to place than typical cube-shaped designs. The **twotwo sub2** uses a proprietary PMC flat diaphragm piston driver in a larger, more conventionally-sized cabinet.

Unpacking and Care

The PMC **twotwo** active subwoofers are packed in heavy-duty protective cartons. Please retain the carton to ensure that the loudspeaker can be transported safely if the need arises in the future. If you dispose of the packaging please do so in an environmentally responsible and safe way.

What's in the Box?

- 1x **twotwo sub1** or **sub2** active subwoofer
- 1x AC mains power cable
- 1x RJ45 control link cable
- 1x User Guide
- 4 x M8 glide feet
- 4 x D-cup isolators*

* The supplied self-adhesive D-cup isolators can be used to cover the M8 holes if the glide feet/spikes are not required.



The twotwo subwoofer products are heavy. Please take care when lifting from the carton. Do not attempt to use the loudspeaker if the packaging has been water-damaged.



Please Note: This unit must be earthed

Care and Service

In normal usage PMC speakers should provide many years of trouble-free operation, but in the unlikely event that you suspect damage or failure has occurred do not attempt to repair the unit yourself.

There are no user-serviceable parts inside. Contact your dealer for advice and a service return address.

Clean the cabinets with a dry and lint-free cloth, and avoid the use of solvents as they may damage the finish of the unit.

Advanced Transmission Line

How it works



PMC's unique **ATL™** (Advanced Transmission Line) enclosures have taken loudspeaker design to the highest level, using sophisticated cabinet construction, proprietary drive units, and patented absorption materials and techniques. The benefits are enormous compared to the relatively simple sealed and ported designs currently available elsewhere.

PMC's innovative approach places the bass drivers near one end of a long cavity (the Advanced Transmission Line). This cavity is heavily damped with acoustic material specified carefully to absorb the upper bass and higher frequencies radiating from the rear of the bass driver. The lowest frequencies are allowed to pass down the line and emerge from the large rear vent which acts essentially as an extra bass driver.

An important benefit of the **ATL™** approach is that the air pressure inside the cabinet, which loads the bass driver, remains consistent. This helps to maintain control of the driver over a wide frequency range and significantly reduces LF distortion. Consequently, the upper bass detail is not masked by harmonic distortion and the result is PMC's characteristically fast, attacking bass, and outstanding clarity.

A further advantage of the ATL design approach is greater bass extension and higher SPL capability compared to typical ported or sealed designs of a similar size – even if similar drivers were used.

Moreover, the very consistent bass driver loading brings the welcome benefit that the frequency response remains consistent regardless of listening level, and analytical auditioning can be conducted without needing high replay volumes just to achieve an optimal bass response. This is a unique and very valuable characteristic of PMC's Advanced Transmission Line.

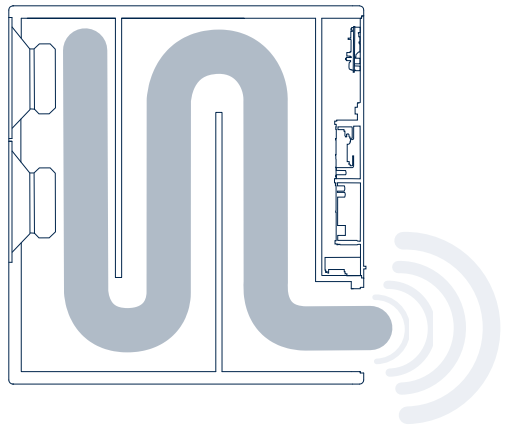

'No other bass loading technology provides such resolution and tonal accuracy at all volume levels'

System Description

All **twotwo** active subwoofers share the same powerful DSP engine, operating at a fixed sample rate of 96kHz.

The two balanced analogue inputs are conditioned by an adjustable low-noise gain stage prior to A-D conversion to optimise the signal-to-noise ratio. The converter is a very high quality delta-sigma device, producing a 24-bit, 96kHz output. The left and right channels are summed to drive the subwoofer speakers, but passed on as separate signals to the analogue outputs.

The AES3 digital input accepts sample rates up to 192kHz, and is sample rate converted to 96kHz automatically. Either channel, or a sum of both, can be selected to drive the subwoofer, and both are passed on to the digital output.

The DSP engine provides the system volume control, low-pass filtering, parametric

equalisation, and phase alignment for the subwoofer, as well as high-pass filtering bass management options for the analogue and digital outputs. It also provides non-invasive excursion limiting to protect the drivers.

The DSP system generates three sets of outputs. In addition to the digital output, there are two separate D-A converters. One converter provides the analogue outputs, while the other feeds a 400W Class-D power amplifier connected to the loudspeaker(s).

The analogue and digital outputs are always available and can be formatted to provide either full range or high-pass filtered signals, which can be used for satellite speakers or other destinations. The output level can be fixed, or follow the system volume control setting.

An optional remote control is available to control the settings and volume of an entire **twotwo** system.

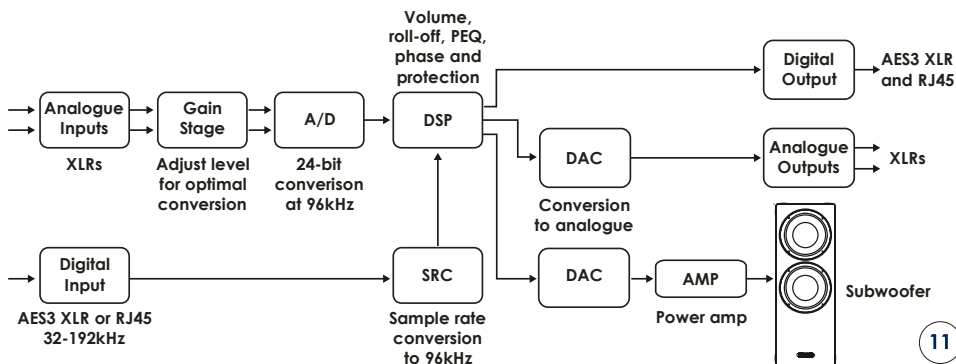

User EQ Options

PMC's **twotwo** active subwoofers feature DSP-based user-equalisation options. These comprise an adjustable low-pass filter to determine the frequency range over which the subwoofer operates, with an adjustable slope which allows perfect integration with the low-frequency response of the stereo satellite speakers. A single-band parametric equaliser can be used to compensate for single resonances or dips in the room response, assisting with in-room alignment.

The low-pass filter can be switched off, or configured with a slope of 6, 12, or 18dB per octave, and with turnover frequencies of 50, 80, 120, 150, or 200Hz, as illustrated in this diagram.



As a starting point when using any **twotwo** active subwoofer with any model of **twotwo** satellite monitor, a low-pass filter setting of 80Hz should give the best integration. However, you may adjust this setting as room conditions and personal preferences dictate.

The centre frequency of the single-band parametric equaliser (PEQ) is adjustable between 20Hz and 150Hz (in 5Hz increments). The bandwidth is variable between $Q=1$ to 8 in 0.5 steps (equivalent to bandwidths of 1.4 to 0.2 octaves). The PEQ gain can be adjusted between a boost of up to +7.87 and a cut of up to -8dB.

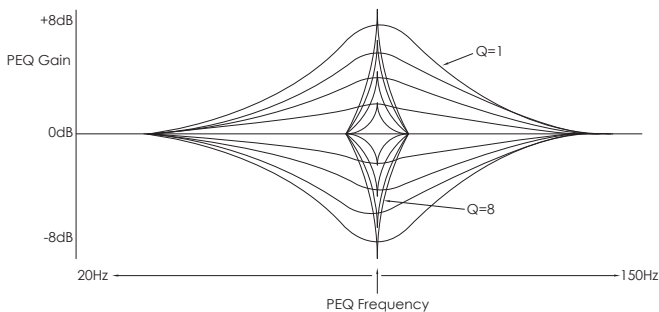

A separate high-pass filter option is included for bass-management of the output signals which may be passed on to satellite loudspeakers. The high-pass filter turnover frequency and slope mirrors the selected low-pass filter settings.

Connections



Caution

To avoid potential damage, please ensure that the signal source is turned off before connecting or disconnecting your **twotwo** active subwoofer.

Connections

The rear panels of all **twotwo** active subwoofers carry the same connectors for audio, control and mains power as described below.

Audio

The two electronically-balanced analogue inputs and the AES3 digital input accept 3-pin male XLR connectors, wired with **Pin-1** screen (ground), **Pin-2** signal positive (hot), and **Pin-3** signal negative (cold). The appropriate input is selected via the rear panel menu system. Each input has a corresponding output which can provide either the full range input signal or a high-pass filtered version, selected via the menu system.

Power

An IEC (C14) mains socket is provided with adjacent power switch. There is no AC voltage selector; **twotwo** active subwoofers accept AC mains voltages between 90-132 and 180-264V.

THIS UNIT MUST BE EARTHED



In - Thru Connections

The 'IN' RJ45 socket accepts volume data and digital audio from the previous **twotwo** speaker in the control chain. The first unit in the chain acts as the Master Volume controller. An optional Remote Control unit can also be connected to the IN socket. The 'THRU' socket sends the control signal to the next speaker in the chain, and also passes the digital audio signal if the first speaker has a valid digital input from either its AES3 or RJ45 'IN' connectors. Note: if the AES3 XLR and RJ45 'IN' are both receiving valid digital audio, the XLR input automatically takes priority.

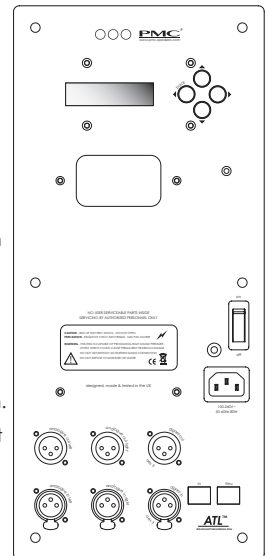

Running-In



When brand new, PMC monitors will take a short period of use before they reach their full potential.

This is because the mechanical and acoustical characteristics of the bass driver alter slightly after manufacture as the flexible surround elements relax and reach their optimum compliancy. Once run-in, the compliancy remains stable and consistent and the **ATL™** cabinet parameters are critically designed to load the bass driver accurately only when it has reached this long-term, optimal compliancy.

Consequently, during the initial running-in period of about 50 hours, the performance of the **twotwo** active subwoofers will change and improve. You will notice the bass tonality becoming fuller, more accurate and neutral, and the bass extension will increase significantly.

50+ hours to run-in

Applications – 2.1 Configurations

All **twotwo** active subwoofers can be used to extend the bass response of any **twotwo** series monitor, or to reproduce the LFE channel in a surround system. The diagrams on the following pages illustrate a variety of configuration suggestions. The configurations and settings described here apply equally to all **twotwo** active subwoofer models.

There are three important points to note. First, the **twotwo** loudspeaker (or optional remote controller) at the start of the control chain acts as the system master controller and sets the volume for the entire system. Secondly, the final loudspeaker in the chain must have the loop-back terminator plugged into the RJ45 Remote Thru socket. Finally, if an AES3 digital input signal is connected to any loudspeaker in the chain the audio data is passed automatically over the RJ45 control line to the next monitor in the chain, and will be used if the AES3 input is selected but not connected on that loudspeaker.

The diagram below illustrates one example of configuring the analogue audio and control connections in a stereo configuration using a **twotwo sub1** active subwoofer to extend the bass performance of **twotwo** active monitors. In this arrangement the left and right analogue inputs are connected to the subwoofer, and the digital output from the subwoofer (suitably high-pass filtered, if desired) is passed on to the satellite **twotwo** monitors via RJ45 cable.

The optional remote controller is shown here as the first item in the control chain, with the loop-back terminator plugged into the RJ45 Thru port on the last device in the control chain (in this case, the front left **twotwo** loudspeaker).

2.1 Configuration, Analogue Source, Digital Link

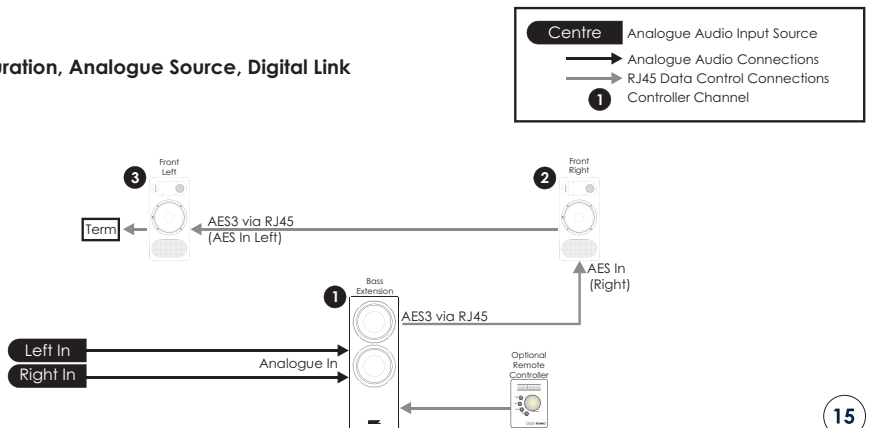

Applications – 2.1 Configurations

2.1 Configuration, Analogue Sources

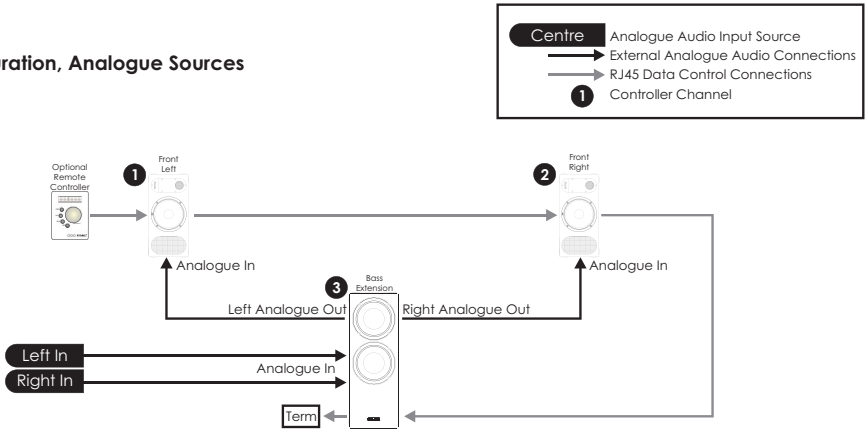

The diagram above illustrates an alternative 2.1 configuration using analogue connections between the subwoofer and loudspeakers, this time with the optional remote controller connected to the front left loudspeaker and the terminator on the subwoofer.

The example below shows a 2.1 setup with a stereo AES3 digital input connected to the subwoofer. By selecting the AES (L+R) mode a mono sum of both channels is used to drive the subwoofer speakers. The left and right audio signals are passed on via an AES3 connection to the digital input of the right satellite monitor where right AES3 channel is selected as the input source. The digital audio signal is automatically passed on to the other monitor via the RJ45 cable carrying the control data where the left AES3 channel is selected and the terminator connected to its RJ45 Thru port.

2.1 Configuration, Digital Sources

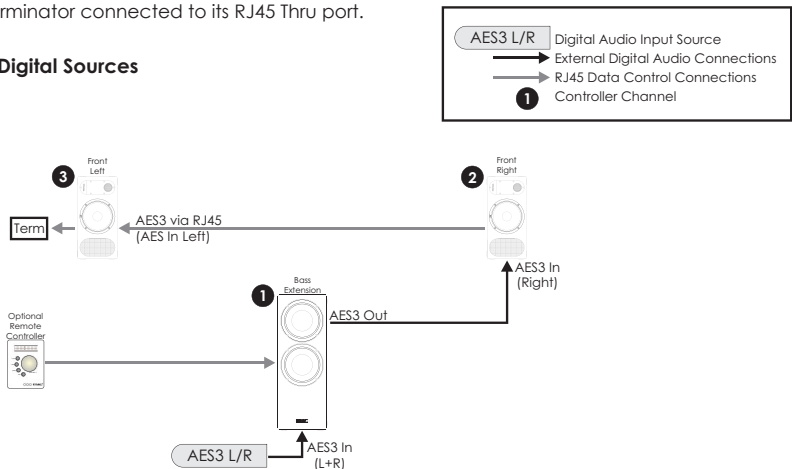

Applications – 7.1 Configurations

7.1 Configuration, Digital Sources

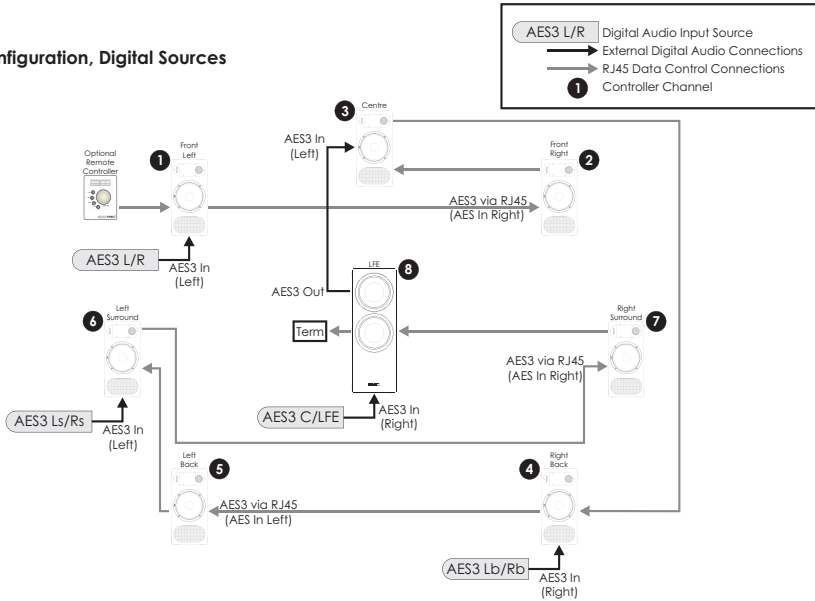

7.1 Configuration, Analogue Sources

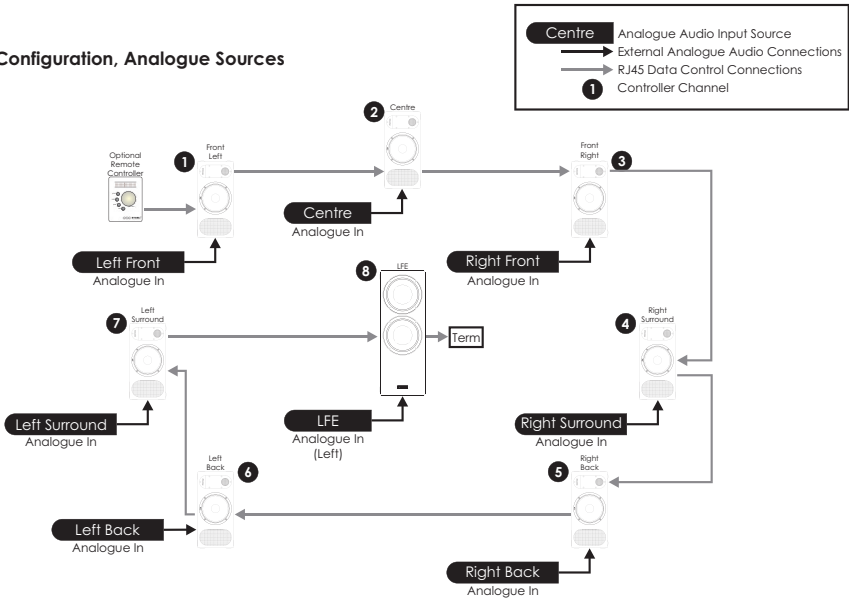

Applications – 5.1 further Configurations

The examples below, and on the next page, illustrate possible configuration arrangements involving two subwoofers – one employed to handle the LFE signal from a 5.1 surround source, and a second used to extend the bass performance of the front stereo pair of satellite monitors.

The same basic principles are employed as previously illustrated in the 2.1 and 5.1 configurations. In the analogue connection example below, the front left and right signals are routed through a subwoofer used to provide bass-extension, before being passed to the front satellite speakers. All of the other channels are connected directly to their respective loudspeakers. The data control chain loops through each of the satellite speakers and then on to the dedicated LFE and bass-extension sub-woofers, the last also having the loop-back terminator attached.

5.1 Configuration, Analogue Sources With Bass Extension

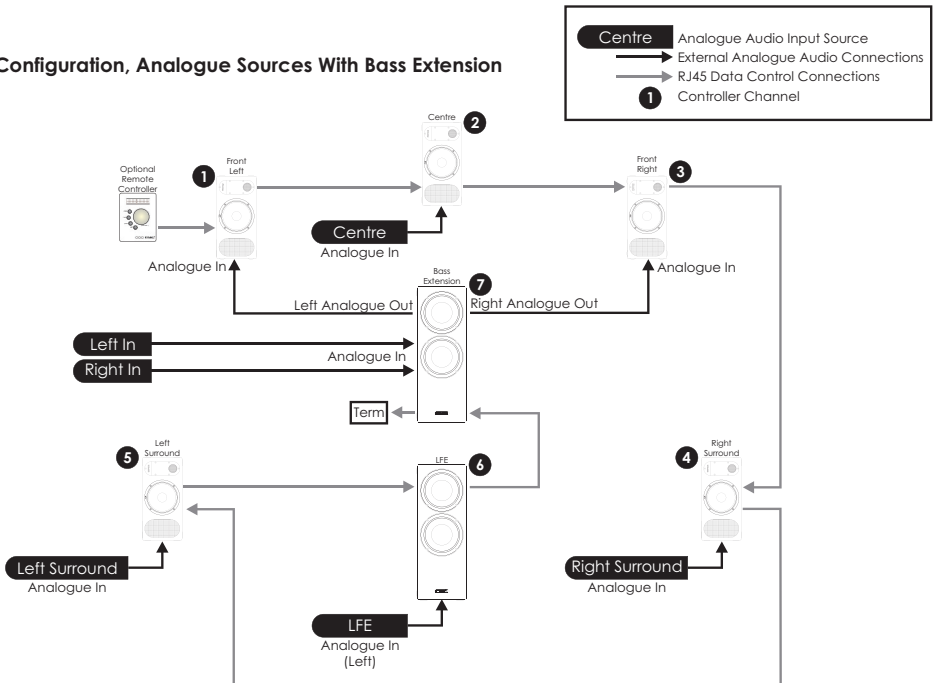

Applications – 5.1 further Configurations

This is the same configuration as the previous page, with separate LFE and bass-extension sub-woofers, but using digital input connections.

The front stereo digital audio signals are connected to the bass-extension sub-woofer, and then routed on to the front left speaker via an AES3 cable. The right channel is conveyed to the right hand speaker via the RJ45 control cable. The centre/LFE channels are connected to the LFE sub-woofer, and an AES3 cable used to pass the centre channel on to the centre speaker.

Left and right surround signals are connected to the right hand surround speaker, with the RJ45 control cable passing the audio over to the left surround speaker. The control cable wiring is slightly more convoluted than the analogue version in order to be able to use it to pass audio channels between consecutive speakers. Alternative configurations are, of course, possible.

5.1 Configuration, Digital Sources With Bass Extension

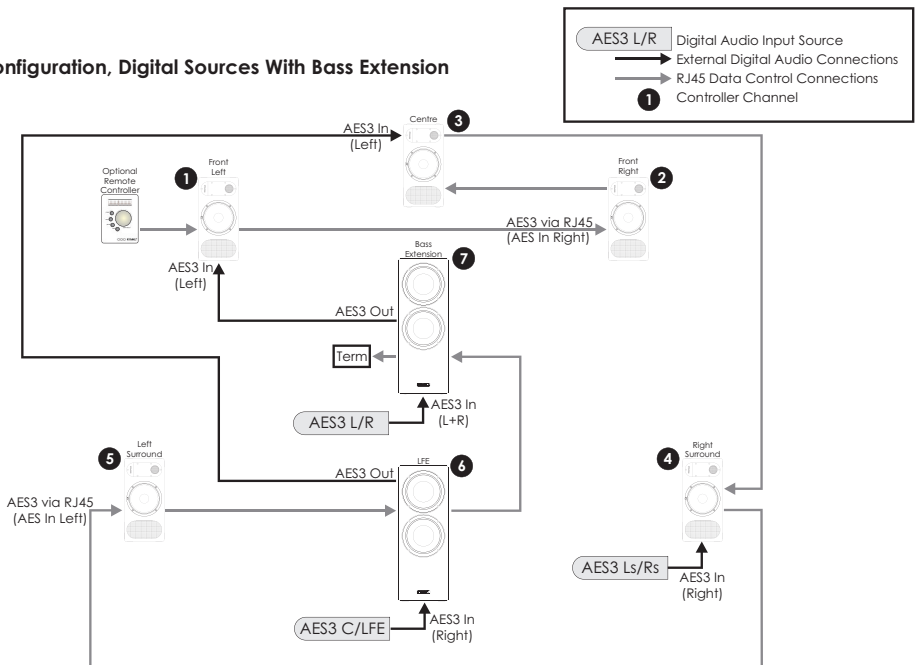

Positioning & Alignment

With their unique **ATL™** cabinet design, ultra-low distortion, and smooth bass roll-off, PMC loudspeakers are more forgiving of difficult room conditions and placement constraints than conventional designs. However, we encourage you to spend some time experimenting in your own room to achieve the very best results, remembering that small changes in location can often influence system performance significantly. The following guidelines are suggestions for a starting point to locate your new subwoofer and optimise its alignment. Fine-tuning can start from there.

Positioning

Since the **twotwo** active subwoofers reproduce frequencies below 150Hz, they don't contribute information towards stereo imaging, and can therefore be placed independently of the main satellite stereo loudspeakers. However, the ideal positioning will be affected by the nature of the room's standing waves.

A simple way of finding the optimal location for the subwoofer is to place it initially at the listening position. Play music or test signals with wide ranging bass notes and move around the potential subwoofer locations listening for the position which gives the most uniform sound with minimal boomy or weak notes. The subwoofer can then be relocated to the most uniform position. Ideally, this will be close to the front wall and somewhere between the two front speakers, but not on the exact centre line.

Alignment

Once the optimal location has been decided, the subwoofer's electrical alignment can be performed. The first parameter to adjust is the low-pass filter frequency and roll-off. These should complement the satellite speaker's low-frequency roll-off.

Next, the Phase can be aligned to ensure that the subwoofer signal through the crossover region arrives at the listening position in-phase with the satellite speakers. A test signal (sine wave tone) is required at a frequency which will be reproduced by both the satellite speakers and subwoofer – typically around 85Hz. The phase control (and if necessary the polarity inversion) should be adjusted to make the tone as loud as possible, indicating proper alignment.

Finally, the level of the subwoofer can be adjusted to provide a smooth and balanced extension to the low-frequency performance of the satellite speakers. When set correctly you will be almost unaware of the subwoofer's contribution, noticing its absence when switched off! If you are aware of it in normal use it is probably turned up too loud!

Specifications*



Input Connectors	Two balanced analogue (left/right) via XLR (female) One AES3 digital (left/right or summed channel selectable) via XLR (female) Input sample rate: 32 -192kHz, 24-bit via internal sample rate converter All XLR-3F connectors wired Pin-1 screen, Pin-2 hot, Pin-3 cold Each input has independent ± 8 dB trim range
Outputs	Two balanced analogue (left/right) via XLR (male) One AES3 digital via XLR(male) Outputs can carry direct or high-pass filtered audio, at fixed or variable level. All outputs are simultaneously available regardless of selected source.
Control	RJ45 sockets carry twotwo system control data and digital audio. Valid AES3 present on the XLR connector overrides RJ45 IN digital audio RJ45 THRU carries same digital audio signal as AES3 output (at 96kHz) The first twotwo system device in the chain is the Master Volume controller An optional Remote Controller is available for twotwo systems
LCD LCD Backlight Timeout	16x2 LCD display and four navigation buttons allow system configuration 30 seconds, 2 minutes, 5 minutes, or Off
System Volume Gain Trim Analogue Input Sensitivity LFE +10dB Gain Mode	-48.5dB to +15dB -8.00dB to +7.87dB +4dB to +20dB (default = +12.5dB) Off/On
Source Selection	Analogue, AES3 Left Channel, AES3 Right Channel, AES3 Left+Right (Subwoofer signal is sum of left and right inputs)
Subwoofer LPF Roll-off Slope Subwoofer Roll-off Frequency	Low-pass filter: Off, 6dB/Oct, 12dB/Oct, or 18dB/Oct 50Hz, 80Hz, 120Hz, 150Hz, or 200Hz

Polarity Invert	Off/On
Phase Alignment	0 to 180 degrees (in 5 degree increments)
Parametric EQ (PEQ)	Off/On
PEQ Gain	-8.00dB to +7.87dB
PEQ Frequency	20Hz to 150Hz (in 5Hz increments)
PEQ Bandwidth	Q adjustable between 1 and 8 in steps of 0.5
Left/Right Output Levels	Fixed/Variable
Left/Right Output Response	High-pass Filtered/Fullrange
Amplifier Section	400W / 4 Ohms (driving two 8 Ohm bass drivers)
Mains Power	IEC connector. 90-132 / 180-264V AC 50 / 60Hz Auto-sensing
Usable Frequency Response	22Hz to 200Hz
Effective ATL™ Length	3m (9.8ft)
Drive units	Two PMC doped 170mm drivers with cast alloy chassis
Cabinet dimensions	H 550 W 200 D 516 (mm) (Add 30mm to height dimension if using glide feet)
Weight	18kg

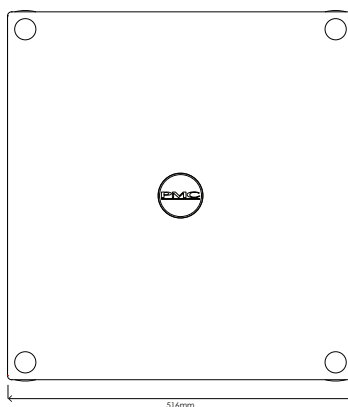
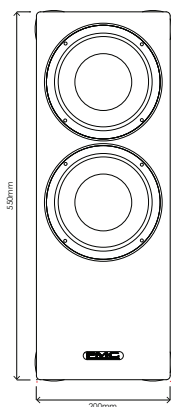

Specifications*



Input Connectors	Two balanced analogue (left/right) via XLR (female) One AES3 digital (left/right or summed channel selectable) via XLR (female) Input sample rate: 32 -192kHz, 24-bit via internal sample rate converter All XLR-3F connectors wired Pin-1 screen, Pin-2 hot, Pin-3 cold Each input has independent ± 8 dB trim range
Outputs	Two balanced analogue (left/right) via XLR (male) One AES3 digital via XLR(male) Outputs can carry direct or high-pass filtered audio, at fixed or variable level. All outputs are simultaneously available regardless of selected source.
Control	RJ45 sockets carry twotwo system control data and digital audio. Valid AES3 present on the XLR connector overrides RJ45 IN digital audio RJ45 THRU carries same digital audio signal as AES3 output (at 96kHz) The first twotwo system device in the chain is the Master Volume controller An optional Remote Controller is available for twotwo systems
LCD LCD Backlight Timeout	16x2 LCD display and four navigation buttons allow system configuration 30 seconds, 2 minutes, 5 minutes, or Off
System Volume Gain Trim Analogue Input Sensitivity LFE +10dB Gain Mode	-48.5dB to +15dB -8.00dB to +7.87dB +4dB to +20dB (default = +12.5dB) Off/On
Source Selection	Analogue, AES3 Left Channel, AES3 Right Channel, AES3 Left+Right (Subwoofer signal is sum of left and right inputs)
Subwoofer LPF Roll-off Slope Subwoofer Roll-off Frequency	Low-pass filter: Off, 6dB/Oct, 12dB/Oct, or 18dB/Oct 50Hz, 80Hz, 120Hz, 150Hz, or 200Hz

Polarity Invert	Off/On
Phase Alignment	0 to 180 degrees (in 5 degree increments)
Parametric EQ (PEQ)	Off/On
PEQ Gain	-8.00dB to +7.87dB
PEQ Frequency	20Hz to 150Hz (in 5Hz increments)
PEQ Bandwidth	Q adjustable between 1 and 8 in steps of 0.5
Left/Right Output Levels	Fixed/Variable
Left/Right Output Response	High-pass Filtered/Fullrange
Amplifier Section	400W rms
Mains Power	IEC connector. 90-132 / 180-264V AC 50 / 60Hz Auto-sensing
Usable Frequency Response	22Hz to 200Hz
Effective ATL™ Length	3m (9.8ft)
Drive units	One 250mm PMC flat diaphragm piston driver
Cabinet dimensions	H 510 W 630 D 377 (mm) (Add 30mm to height dimension if using glide feet)
Weight	40kg

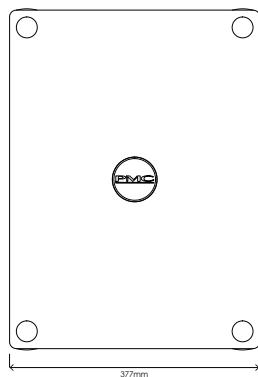
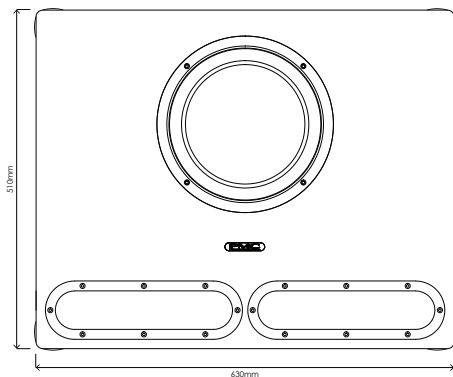

Operational Controls

The **twotwo** active subwoofers are configured and controlled via a simple menu system which is viewed on the rear panel display and navigated by four associated push-buttons. The first loudspeaker in a **twotwo** series chain acts as the master volume controller.

Looking at the four cursor buttons, the left and right buttons step back (exit) and select (enter) the menu options, respectively, while the upper and lower buttons scroll through the various menu options and adjust the parameter values. The menu structure is simple, logical and intuitive, and uses clear display legends to indicate the selected function and parameter.

When the **twotwo** active subwoofer is connected to a mains supply it will power-up with the default display. Pressing any of the four rear panel buttons will turn the system on. The factory default settings will initially configure the subwoofer to use the analogue XLR inputs, with the input sensitivity set to +12.5dB, Trim 0dB, all the equalisation set flat, backlight timeout 2 minutes, and the volume set to -20.5dB.

Factory Reset

The factory default settings can quickly be restored by pressing and holding the Up and Down buttons simultaneously for more than 2 seconds.

Default Display

With the loudspeaker switched on, the LCD window normally indicates the current volume level and the selected low-pass filter frequency and slope. The system volume is indicated in decibels on the upper line of the display, within the range -48.5 to +15dB. To increase or decrease the current volume level press the up/down buttons. The LF roll-off settings are displayed on the second line, with the roll off frequency followed by the slope.

V	o	l	u	m	e	-	2	0	.	5	d	B		
L	F		R	o	l		O	f	f					

Power Mode

By pressing the right (enter) button, the next menu level is accessed which accesses the power standby mode. By pressing the right button again, power standby is selected and the LCD will show 'Zzz' to indicate the standby (Sleep) condition. The backlight will switch off.

Z	z	z												

NOTE: The loudspeaker can be activated again by pressing any rear panel button.

Setup Mode

Pressing the right (enter) button twice from the default volume display accesses the Setup menu, and the up/down buttons can then be used to access the various options.

S	e	f	u	p															
+	1	0	d	B		G	a	i	n										

After selecting the desired option pressing the right button again displays the current parameter value, and the up/down buttons can be used to alter the value. Pressing the left (exit) button exits the parameter level and allows other options to be selected.

+	1	0	d	B		G	a	i	n										
O	f	f																	

Set Up Menu Options:

+10dB Gain	Introduces +10dB gain to suit Dolby Digital LFE requirements
Phase Rev	Polarity inversion, Off or On
Phase	Phase alignment from 0 to 180 degrees in 5 degree increments
Paramtric EQ	Switches single paramtric EQ band Off or On
PEQ Gain	Adjusts parametric EQ gain (-8.00dB to +7.87dB)
PEQ Frequency	Adjusts parametric EQ centre frequency (20Hz to 150Hz)
PEQ Q	Adjusts parametric EQ bandwidth (Q=1 to 8)
BL Timeout	Sets the time after which the LCD backlight will switch off. Options: 30 sec, 2 min, 5 min, off (no timeout)
Trim	Input trim level (-8.00dB to +7.87dB)
Analogue In Sens	Input sensitivity (+4dB to +20dB)
Source	Selects input source (Analogue XLR, AES3 Left Channel, AES3 Right Channel, AES3 L+R)
LR Out Level	Fixed or variable
LR Out Response	Filtered or Full Range
LF Rolloff Slope	Off, or 18, 12 or 6dB/Octave
LF Rolloff Freq	Selects the low-pass roll-off turnover frequency Frequency options: 50, 80, 120, 150, or 200Hz

Default Display	Up/Down	Press Right	Up/Down	Press Right	Display	Up/Down	Press Right	Up/Down	Default
Volume +xx.xdB*	-48.5 to +15dB	-							-20.5dB
LF Roll f#Hz / xx **	PMC twotwo PMC Sub Setup	-	+10dB Gain	-			Off / On	Off / On	Off
			Phase Reverse	-			Off / On	Off / On	Off
			Phase	-			0 – 180 degrees		0
			Parametric EQ	-			Off / On		Off
			PEQ Gain	-			-8.00dB to +7.87dB		0
			PEQ Freq	-			20Hz – 150Hz		20Hz
			PEQ Q	-			1 – 8		1
			BL Timeout	-			2 min		2 min
				-			30 sec		
				-			Off (no timeout)		
				-			5 Min		
			Trim	-			-8.00dB to +7.87dB		0
			Analogue In Sens	-			+4dB – +20dB		+12.5dB
			Source	-			Analogue		Analogue
				-			AES3 Chan L+R		
				-			AES3 Chan Right		
				-			AES3 Chan Left		
			LR Out Level	-			Fixed / Variable		Fixed
			LR Out Response	-			Filtered / Full Range		Filtered
			LF Roll-off slope	-			Off		Off
				-			18dB/Oct		
				-			12dB/Oct		
				-			6dB/Oct		
			LF Roll-Off Freq	-			50Hz		50Hz
				-			200Hz		
				-			150Hz		
				-			120Hz		
			PMC twotwo sub Power Off	-	Zzz		80Hz		

* 1st amplifier in chain is master volume controller

** 2nd line of display shows LPF roll-off frequency and slope in dB/octave

All menus return to default after 60 seconds of button inactivity

Pressing volume up and volume down together >2 sec whilst in default menu returns menus to factory defaults

First power-up from the mains switch boots speaker and default display

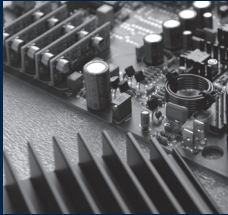

Service

We are confident that your **twotwo** active subwoofer will afford many years of trouble-free listening of the highest order. However, in the unlikely event of requiring repair all replacement parts will exactly match the performance of those originally installed because we record the precise value of each component along with the system response as a whole for every loudspeaker we produce.

For any issues that might arise, or for advice and service requirements, the primary point of contact should be your authorised PMC dealer/distributor.

If you do not have a local representative please see www.pmc-speakers.com and click on 'Where to buy.'

Alternatively you can view the FAQ's (Frequently Asked Questions) and servicing section on our website. (Click on the 'contacts' section and select 'FAQ').



Important Note: Please do not return any products to PMC directly without first contacting our service department by email at service@pmc-speakers.com

The PMC Range

The PMC range of professional monitors currently spans 25 different models, from the enormous BB5 XBD-A flagship system down to the diminutive **twotwo.5** speaker. However, every monitor is designed with the same care and attention, using shared families of drive units, crossover designs and amplifiers. As a direct consequence they all enjoy the same family characteristics of wide dispersion, low distortion, consistent voicing, and an even bass response regardless of listening level. This feature allows different sizes of monitors to be used in concert to create effective multichannel systems where space is at a premium.

The **twotwo** series of active PMC monitors share the same core DSP signal processing, class-D amplification, and ability to operate in either vertical or horizontal orientations without compromising the stereo imaging or tonality. The range currently comprises three two-way monitors with 5, 6 and 8-inch bass drivers for near and mid-field applications, plus two dedicated system subwoofers to facilitate 2.1 stereo systems or larger surround systems. An optional remote controller is also available, as is PMC's bespoke surround-capable Monitor Control system which includes comprehensive bass management facilities.

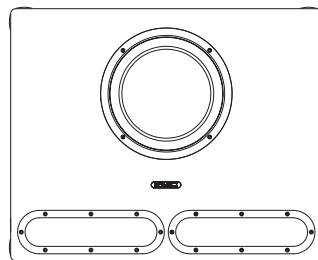
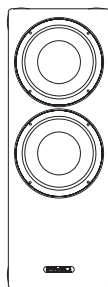
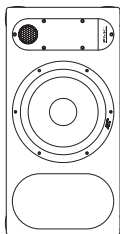
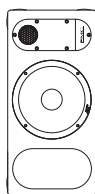
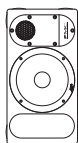
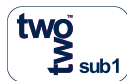

Our Meticulous Care and Attention

All PMC loudspeakers are hand-built in the U.K. using components that are individually matched to our reference model. This includes the structural integrity of every cabinet, and the testing and recording of each individual component to guarantee adherence to our strict tolerances. In this way we can ensure your purchase sounds identical to the original design.

Each completed loudspeaker then undergoes a set of objective and subjective measurements. For example, frequency response sweeps ensure that the unit meets our exacting performance criteria, and critical listening tests are conducted against the reference model using a wide variety of audio material, from a benchmark BBC speech recording to carefully selected classical music, pop and rock tracks.



Inspection Checks

Every component employed within a PMC product is measured, tested, matched and recorded by hand. This analysis also applies to the final product to ensure you receive an identical replica of the original reference model.

- Enclosure finish
- Assembly & Wiring
- Driver installation
- Enclosure seal
- Level – Frequency
- Listening test 1
- Listening test 2
- Final inspection
- Accessory pack
- User Guide

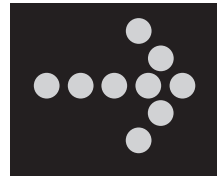

These have all been carefully checked by the builder of your **twotwo** active subwoofer.

Warranty On-Line

PLEASE ACTIVATE YOUR 5-YEAR
WARRANTY ON-LINE

GO TO WWW.PMC-SPEAKERS.COM AND CLICK ON 'REGISTER A PRODUCT'



If you do not have access to the Internet please fill in the Warranty form on pages 34 and 35, and return to PMC.

WARRANTY CERTIFICATE - PART 1

Your copy
to keep

Please complete and retain this page for your own records

Product

Serial No's

Date of purchase

Dealer's name

Dealer's address

Town

County

Postcode

Dealer's Telephone No.

Servicing and warranty issues – Please read the following carefully.

Non-UK clients

Contact your local dealer/distributor for the details of warranty repairs – see www.pmc-speakers.com and click on "Where to buy".

UK clients

In the unlikely event of a fault occurring with your PMC product please contact your dealer where the product was purchased.

Do not return a product to PMC without firstly contacting our technical department. If the product needs to be returned for service you will be issued with a Returns Authorisation number.

If a product is returned to PMC and subsequently is found to have no fault or a non-warranty fault there will be minimum charge of £50.00 plus the carriage for its return.

Proof of purchase is required for any claim covered by this warranty.

This product is warranted for a period of five years from the date of purchase or valid warranty registration which is either by receipt of the 'Our Copy' card or an on-line registration which must be made within ten days of purchase or receipt.

The warranty covers defects due to faulty materials or workmanship but does not cover defects arising from accidental damage, misuse or wear and tear. The warranty is void if any attempt has been made by persons not authorised by PMC to dismantle, repair or modify any part of the product.

Products must be returned using original packing material. This warranty does not cover damage in transit.

Note that the cost of the carriage to PMC is not covered by the warranty.

Returned products that are defective but no longer covered by warranty will be repaired or replaced at the discretion of PMC.

Please allow a minimum of 14 working days for return of warranty repairs.

This warranty does not affect your consumer rights under statutory law. This warranty certificate is only valid in the United Kingdom.

THE PROFESSIONAL MONITOR COMPANY LTD, HOLME COURT, BIGGLESWADE, SG18 9ST, UK T +44 (0) 870 4441044 F +44 (0) 870 4441045

WARRANTY CERTIFICATE - PART 2

PMC's copy

Please complete and return this section – or simply complete the on-line registration at www.pmc-speakers.com and click on 'Register A Product.'

Help us to improve
our products.
See over

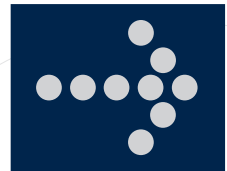

Help us Improve. Your Comments?

We value all of our clients' comments. Please take a moment to help us improve:

If there is one thing we should change, what would it be?

Please tell us how your new PMC loudspeakers perform. Your comments may appear on the customer quotes section for this product on our website – but don't worry, the comments will be anonymous and your personal details will not be published.

Which magazines do you read?

HiFi

HiFi Choice

What HiFi

Stereophile

HiFi World

HiFi Critic

HiFi News

HiFi+

Gramophone

Pro

Future Music

Sound On Sound

Audio Media

Pro Sound News

Resolution

Audio Fanzine

IBE

Tape Op

Lifestyle

T3

Stuff

GQ

Mens Health

FHM

Loaded

Maxim

Esquire

On-Line

mixonline.com

gearslutz.com

avreview.co.uk

avforums.com

HiFi WigWam.com

What HiFi.com

SoundonSound.com

SoundonSound/forum

'We hope you enjoy your latest purchase as much as we enjoyed designing and building them – Thank you'

Notes

A series of 18 horizontal dotted lines for writing notes.

Notes

A series of 18 horizontal dotted lines for writing notes.



twotwo is a trademark of The Professional Monitor Company Limited.

This document should not be construed as a commitment on the part of The Professional Monitor Company Limited.

The Professional Monitor Company Limited will not assume responsibility for errors that may appear in this document.

Information may be subject to change.

